

AVTOMABILLARNI 3M STRUKTURALI ULASH LENTASI BILAN MAXKAMLANUVCHI PLASTINA TUTQICHI KONSTRUKSIYALARINI TAXLILI

Toshqo'ziyeva Zulfiya Eraliyevna

Farg'ona politexnika instituti katta o'qtuvchisi

toshquziyeva.zulfiya@gmail.com

Muxtorov Sherzodjon Sobirjon o'g'li

Farg'ona politexnika instituti assistanti

muxtorovsherzod1995@gmail.com

Annotatsiya. Ushbu maqolada avtomabillarni old oynasiga maxkamlanuvchi ya'ni orqani ko'rish uchun mo'jalangan ko'zguni old oyna bilan bog'lab turuvchi plastina tutqichlarini konstruksiyalari va kamchliklarini oldini olish bo'yicha tavsiyalar berilgan.

Kalit so'zlar: old oyna , 3M strukturali ulash lentasi, plastina tutqich.

Annotation. This article provides advice on how to avoid the design and defects of plate handles that attach to the windshield, which connects the rear-view mirror to the windshield.

Keywords: windshield, 3M structural tape, plate holder.

Аннотация. В данной статье даны советы, как предотвратить дефекты конструкции и дефекты планки-ручки, крепящейся к лобовому стеклу, которая соединяет зеркало заднего вида с лобовым стеклом.

Ключевые слова: лобовое стекло, структурная лента 3М, пластинодержатель.

Mashinasozlik sanoati rivojlanib brogan sari ishlab chiqarilayotgan mashina va mexanizimlar, ularni sifati, ish unumdorligi, ishlash muddatlariga talab kundan kunga ortib bormoqda. Shu navbatda avtomobillarni old oynasiga maxkamlanuvchi orqani ko'rish uchun mo'jalangan ko'zguni old oyna bilan maxkam ushlab turuvchi plastina tutqichiga bo'lgan talab ortib borayotgani ko'rishimiz mumkin. Bunga

sabab avtomobilda harakatlanish mobaynida orqada kelayotgan avtomobilni va orqaga harakatlanishni kuzatib borish uchun xizmat qiladi.



1-rasm. Hozirgi kundagi yetakchi avtomobil ishlab chiqaruvchi zavodlarini avtomobillari uchun ishlatiladigan old oynalar.

Mashinasozlikda avtomobillar ishlab chiqarish sanoati qanchali rivojlangan sari, avtomobillar old oynasiga maxkamlanuvchi plastina tutqichiga bo'lgan talab ham kuchayib boryapti. Sabab ko'zgularni zamonaviy korinishlari va konstruksiyalari rivojlanib kelmoqda. Shu o'rinda yangi turdagi plastina tutqichlari konstruksiyasiga bo'lgan talab ham o'sib bormoqda. Hozirgi kundagi avtomobillar uchun plastina tutqichilarni turlarini 2-rasmda ko'rsarilgan.



2-rasm. Zamonaviy avtomobillarni 20 xil turdagi plastina tutqichlarini ko'rinishlari.

Umumiy ish sharoitida plastina tutqichi biriktirish pnevmatik moslamada 30-50 N/sm bosim bilan amalga oshiriladi. Odatda ushlab turish shartlari 140°C da 10 sekund. Bu oddiy avtoklav jarayonlariga javob beradi.

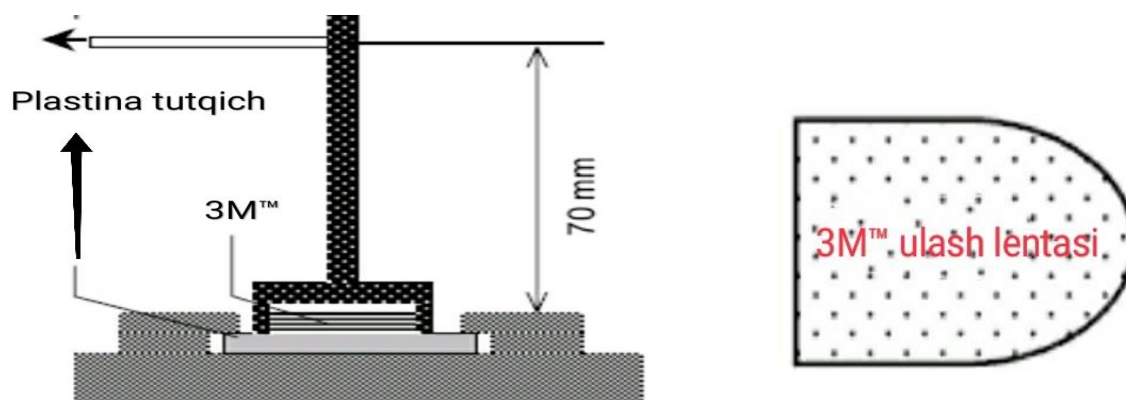

3-rasm. 3M strukturali ulash lentasini plastina tutqichiga yopishtirish sxemasi.

Ushbu jarayonda 3M strukturali ulash lentasini plastina tutqichiga yopishtirish jarayoni ko'rsatilgan. Bu texnologik jarayonda 3M strukturali ulash lentasini avtomatik liniyada pnevmatik moslama yordamida plastina tutqichlarga mos perimetrda kesib joylab boradi. Bu pnevmatik moslama universal bo'lib, har qanday turdagi plastina tutqichiga moslasa bo'ladi. Hozirgi kundagi avtomobil ishlab chiqaruvchi zavodlar o'z avtomobillari uchun 3M strukturali ulash lentasidan foydalanadi.

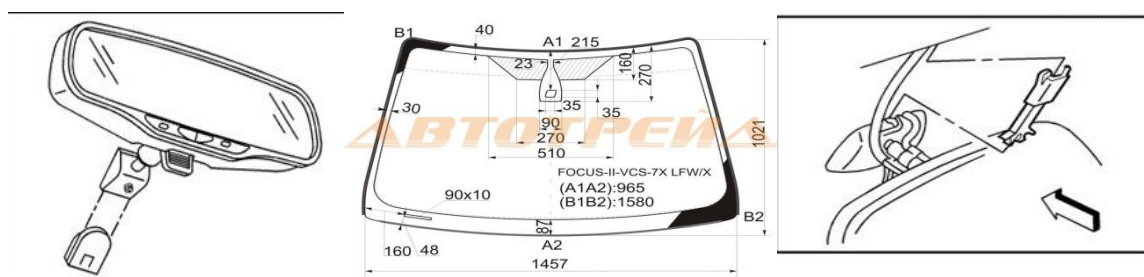

4-rasm. Avtomobil old oynasiga 3M strukturali ulash lentasi orqali plastina tutqichini maxkamlab ko'zguni o'rnatish sxemasi va parametri.

Old oynaga plastina tutqichini maxkamlangandan keyin ko'zguni plastina tutqichiga kirgizib maxkamlash sxemasi ko'rsatib o'tilgan. Ushbu yig'ish jarayonida

parametrlarga asosan yig'ish lozim. Sabab ko'zgu old oyna yuqori qismida hamda markazida bo'lishi lozim.

3M strukturali ulash lentasini ikki xil turidan avtomobil ishlab chiqarishda foydalaniladi. 3M germetik va lentali turlaridan plastina tutqichi uchun lentalisidan foydalaniladi.



5-rasm. 3M strukturali ulash lentasini germetik va lentali turlari.

Ushbu ulash lentasi orqali barcha turdagi plastina tutqichlarni oynaga maxkamlash uchun foydalanish mumkin. Hozirgi kundagi zamonaviy avtomobillar ishlab chiqaruvchi zavod talablariga to'la javob beradi.

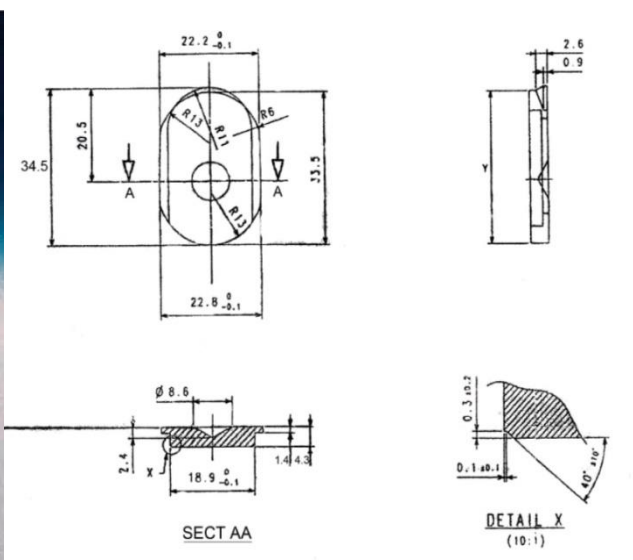

6-rasm. №9263 sonli avtomobil plastina tutqichi chizmasi.

Bu plastina tutqich №9263 sonli plastina tutqichi xisoblanadi. Ushbu plastina tutqich Uz.DAEWOO zavodida Tiko, Matiz, Nexia avtomobillari uchun ishlatilgan.

Avzaligi pastga tepaga ko'zguvni harakatini cheklovchi chuqurcha mavjudligi. Kamchiligi yuk ko'tara olish qobilyati pastligi. Sabab old oynaga yopishuvchi yuzasi kichikligi va yopishuvchi yuzasi aniqligi pastligidadir.

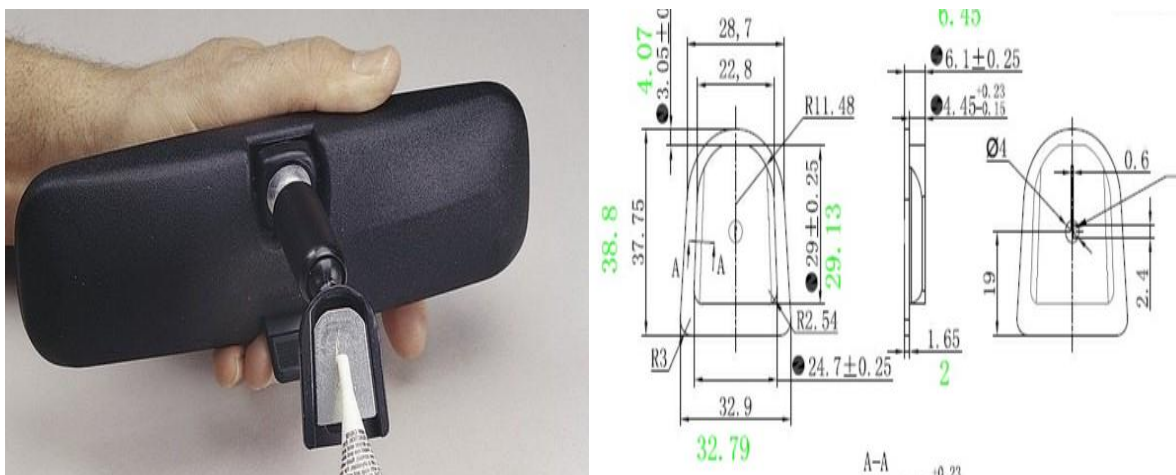

7-rasm. №9270 sonli avtomobil plastina tutqich chizmasi.

№9270 sonli avtomobillar plastina tutqichi xisoblanadi. Ushbu turdagi plastini tutqichlar GM zavodi avtomobillaridan Coblt, Nexia 3R larga ishlatiladi. Kamchiligi avtomat karobka avtomobillar uchun ishlatilmaydi. Sabab ko'zguni original variantiga mos kelmaydi. Afzalligi old oynaga maxkamlangan(№9270) plastinaga kirish jarayonida oynada kirish chizig'i hosil qilmaydi.



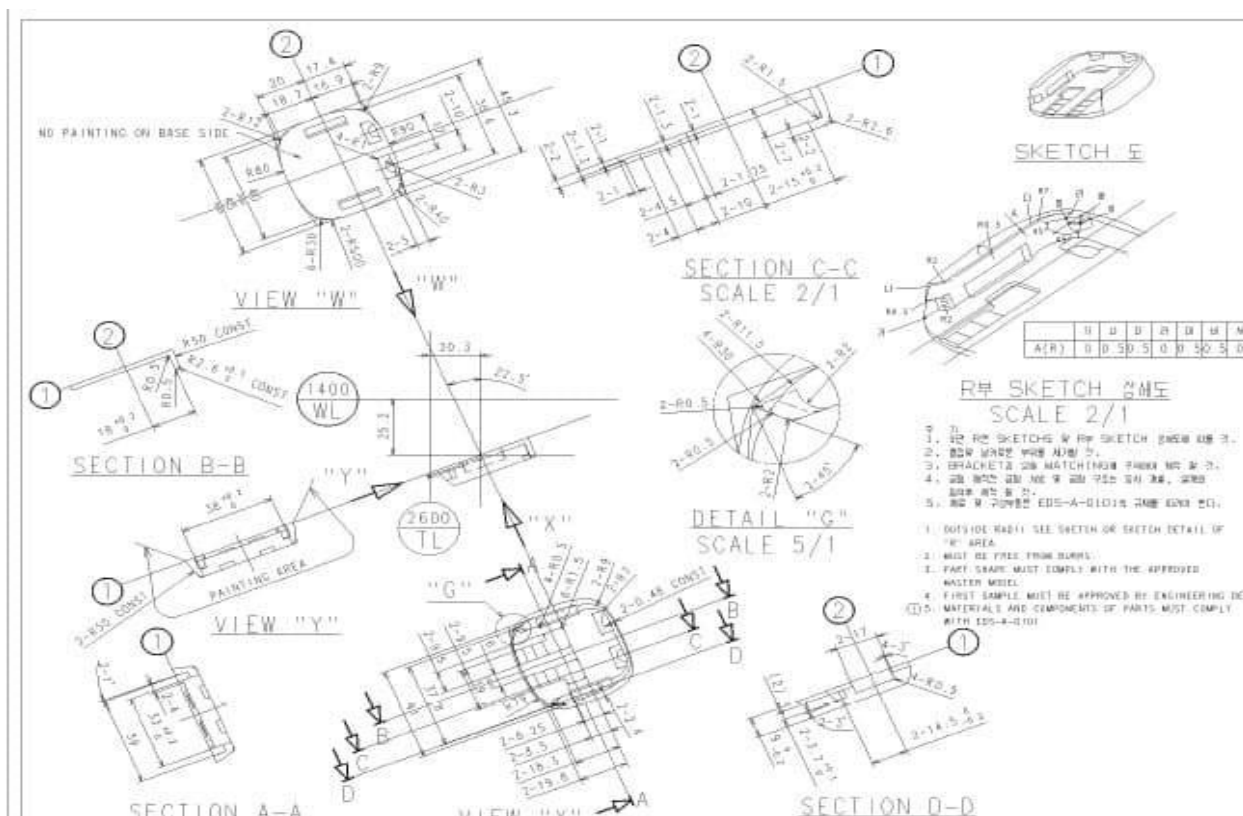

Bu turdagi plastina tutqichlar GM (O'zbekiston) Zavodida ishlab chiqaruvchi avtomabillardan Lacetti, Malibu avtomabillari uchun ishlatiladi. №193561 sonli plastina tutqichi bo'lib, tirovchi detallarni qisib qoluvchi ariqchasi mavjudligi foydali taraflaridan biri bo'lib xizmat qiladi.

Foydalanilgan adabiyotlar

1. Eraliyevna, T. Z. (2020). Development trends in the building complex in Uzbekistan. *ACADEMICIA: An International Multidisciplinary Research Journal*, 10(6), 1702-1705.
2. Mamajonovich, K. A., Eraliyevna, T. Z., & Mukhtaraliyevna, R. M. (2020). Box curve (curl) of fan casing. *ACADEMICIA: An International Multidisciplinary Research Journal*, 10(5), 604-607.
3. Eraliyevna, T. Z., & Shavkatbekovna, G. E. (2021). History, concept and origin of architectural art. *ACADEMICIA: An International Multidisciplinary Research Journal*, 11(6), 714-716.

4. Eraliyevna, T. Z. (2021). History of architecture city and ferghana cities in the region. CENTRAL ASIAN JOURNAL OF SOCIAL SCIENCES AND HISTORY, 2(2), 11-15.
5. Хусанбоев, А. М., Тошкузиева, З. Э., & Нурматова, С. С. (2020). Приём деления острого угла на три равные части. Проблемы современной науки и образования, (1 (146)).
6. Toshqo'zieva, Z. E., Nurmatova, S. S., & Madaminov, J. Z. (2020). FEATURES OF USING INNOVATIVE TECHNOLOGIES TO IMPROVE THE QUALITY OF EDUCATION. Theoretical & Applied Science, (5), 213-217.
7. Mukhtorov Sherzodjon Sobirjon ugli, & Srojidinov Jurabek Ravshanjon ugli. (2022). DISTRIBUTION OF THE NUMBER OF FAULTS AND TIME OF RESTORATION OF ELEMENTS OF SEWER NETWORKS. Galaxy International Interdisciplinary Research Journal, 10(1), 448–454. Retrieved from <https://internationaljournals.co.in/index.php/giirj/article/view/1053>
8. Mukhtorov Sherzod Sobirjon ugli, & Srojidinov Jurabek Ravshanjon ugli. (2022). ANALYSIS OF THE IMPACT OF EARTHQUAKES ON THE RELIABILITY OF UNDERGROUND PIPELINES. Galaxy International Interdisciplinary Research Journal, 10(1), 436–441. Retrieved from <https://internationaljournals.co.in/index.php/giirj/article/view/1051>
9. Mukhtorov Sherzodjon Sobirjon oglu. (2022). ANALYSIS OF CAR PLATE HOLDER CONSTRUCTIONS. Galaxy International Interdisciplinary Research Journal, 10(1), 442–447. Retrieved from <https://internationaljournals.co.in/index.php/giirj/article/view/1052>
10. Mukhtorov Sherzodjon Sobirjon ugli. (2022). IMPROVING THE STRENGTH OF DETAILS BY CHROMING THE SURFACES. Galaxy International Interdisciplinary Research Journal, 10(1), 455–461. Retrieved from <https://internationaljournals.co.in/index.php/giirj/article/view/1054>

11. Mukhtorov Sherzodjon Sobirjon ogli. (2022). GASEOUS NITROGENATION. *Galaxy International Interdisciplinary Research Journal*, 10(1), 462–467. Retrieved from <https://internationaljournals.co.in/index.php/giirj/article/view/1055>
12. Todjiboyev R.K., Ulmasov A.A., & Muxtorov Sh. (2021). 3M structural bonding tape 9270. *Science and Education*, 2 (4), 146-149.
13. Sherzod Sobirjon O’G’Li Muxtorov, & Islombek Ikromjon O’G’Li Qoxxorov (2022). Issiqlik almashuvchi qurilmalar va ularda jarayonni intensivlash usullari tahlili. *Science and Education*, 3 (5), 370-378.
14. Арзиев, С. С., & Тохиров, И. Х. Ў. (2021). ФАЗОВИЙ ФИКРЛАШНИНГ БЎЛАЖАК МУҲАНДИС ВА АРХИТЕКТОРЛАР ИЖОДИЙ ФАОЛИЯТИДА ТУТГАН ЎРНИ. *Scientific progress*, 2(2), 438-442.
15. Kholmurzaev, A. A., & Polotov, K. K. (2020). METHODS OF USING MEDIA EDUCATION IN THE LEARNING PROCESS. *Theoretical & Applied Science*, (5), 205-208.
16. Kholmurzaev, A. A., & Tokhirov, I. K. (2021). The active participation of students in the formation of the educational process is a key to efficiency. *ACADEMICIA: An International Multidisciplinary Research Journal*, 11(4), 435-439.
17. Polotov, K. K. (2020). FEATURES OF TEACHING ENGINEERING AND COMPUTER GRAPHICS. *Theoretical & Applied Science*, (6), 573-576.
18. Tokhirov, I. K. U. (2021). SELECTION OF THE MANUFACTURING PROCESS OF THE PART. *Oriental renaissance: Innovative, educational, natural and social sciences*, 1(10), 698-704.
19. Abdullayev, B. X., & Rahmankulov, S. A. (2021). Movement of Variable Flow Flux Along the Path in a Closed Inclined Pipeline. *CENTRAL ASIAN JOURNAL OF THEORETICAL & APPLIED SCIENCES*, 2(12), 120-126

20. Xolmurzayev, A. A., & Toxirov, I. X. (2021). TALABALARNING O'QUV JARAYONINI SHAKILLANTIRISHDA KOMPYUTERLI O'QITISH TEXNOLOGIALARINI O'RNI. Oriental renaissance: Innovative, educational, natural and social sciences, 1(11), 283-288.
21. Axmadbek Maxmudbek o'g'li Turg'unbekov, & Abdumajidxon Murodxon o'g'li Muxtorov (2021). Theoretical Studies Of The Technological Process Of Machining Parts With Concave Surfaces Of Complex Forms On Cnc Milling Machines. Journal of Innovations in Social Sciences 1(1) ,90-97.
22. Turg'unbekov Axmadbek Maxmudbek o'g'li (2021). THEORETICAL STUDIES OF THE TECHNOLOGICAL PROCESS OF MACHINING PARTS WITH CONCAVE SURFACES OF COMPLEX FORMS ON CNC MILLING MACHINES. 1(8), 122-128.
<https://doi.org/10.5281/zenodo.5710406>
23. Alisher Axmadjon o'g'li Botirov, & Axmadbek Maxmudbek o'g'li Turg'unbekov. (2021). EXPERIMENTAL STUDIES OF THE TECHNOLOGICAL PROCESS OF PROCESSING CONCAVE SURFACES OF COMPLEX SHAPES. Eurasian Journal of Academic Research, 1(8), 222–231. <https://doi.org/10.5281/zenodo.5727625>
24. Botirov, Alisher Akhmadjon Ugli , & Turgunbekov, Akhmadbek Makhmudbek Ugli (2021). INVESTIGATION OF PRODUCTIVITY AND ACCURACY OF PROCESSING IN THE MANUFACTURE OF SHAPING EQUIPMENT. Oriental renaissance: Innovative, educational, natural and social sciences, 1 (11), 435-449.
25. Abdullayeva, Donoxon Toshmatovna, & Turg'unbekov, Axmadbek Maxmudbek O'G'Li (2021). ПРОДЛЕНИЕ СРОКА ХРАНЕНИЯ ЛИСТОВЫХ ДЕТАЛЕЙ ПРОКАТНОГО ОБОРУДОВАНИЯ. Oriental renaissance: Innovative, educational, natural and social sciences, 1 (11), 1035-1045.

26. I. O. Ergashev, R. J. Karimov, A. M. Turg'Unbekov, & S. S. Nurmatova (2021). ARRALI JIN MASHINASIDAGI KOLOSNIK PANJARASI BO'YICHA OLIV BORILGAN ILMIY TADQIQOTLAR TAHLILI. *Scientific progress*, 2 (7), 78-82.
27. Ахмадбек Махмудбек Ўғли Турғунбеков (2021). НОТЕХНОЛОГИК ЮЗАНИНГ ТЕШИКЛАРИГА ИШЛОВ БЕРИШДА ДОРНАЛАШ УСУЛИНИ ТАДБИҚ ЭТИШ. *Scientific progress*, 2 (1), 4-10.
28. Abdumajidxon Murodxon O'G'Li Muxtorov, & Axmadbek Maxmudbek O'G'Li Turg'Unbekov (2021). VAKUUM XALQALARI UCHUN SILIKON MATERIALLARNI TURLARI VA ULARNING TAHLILI. *Scientific progress*, 2 (6), 1503-1508.
29. Усманов, Д. А., Умарова, М. О., Абдуллаева, Д. Т., & Рустамова, М. М. (2021). Исследование процесса очистки и хранения тонковолокнистого хлопка от сорных примесей. *Бюллетень науки и практики*, 7(3), 212-217.
30. Усманов, Д. А., Холмурзаев, А. А., & Умарова, М. О. (2020). Исследование эффективности очистки тонковолокнистых сортов хлопка-сырца. *Проблемы современной науки и образования*, (1 (146)).
31. Мадаминов, Ж. (2021). Бўлажак муҳандисларни лойиҳалаш компетенцияларини компьютер графикаси воситасида ривожлантириш методикасини такомиллаштириш. *Общество и инновации*, 2(8/S), 462-469.
32. Azim o'g'li, V. D., & Nosirjonovich, O. Z. (2022). A Method of Calculating the Depth of Cut in A Lathe After Rolling on A Rough Part. *Eurasian Journal of Engineering and Technology*, 3, 6-11.
33. Muxtoraliyeva, R. M., Nosirjonovich, O. Z., & Zafarjonovich, M. J. (2020). Use of graphics computer software in the study of the subject" Drawing and

- engineering graphics”. *ACADEMICIA: An International Multidisciplinary Research Journal*, 10(5), 83-86.
34. . Валихонов, Д. А. Ў., Ботиров, А. А. Ў., Охунжонов, З. Н., & Каримов, Р. Х. (2021). ЭСКИ АСФАЛЬТО БЕТОННИ КАЙТА ИШЛАШ. *Scientific progress*, 2(1), 367-373.
35. 35. Muxtoraliyeva, R. M., Nosirjonovich, O. Z., & Zafarjonovich, M. J. (2020). Use of graphics computer software in the study of the subject" Drawing and engineering graphics”. *ACADEMICIA: An International Multidisciplinary Research Journal*, 10(5), 83-86.
36. Турғунбеков, Ахмадбек Махмудбек Ўғли, & Сирожидинов, Жўрабек Равшанжон Ўғли (2022). ДЕТАЛ ЮЗАЛАРИНИ АЗОТЛАШ УСУЛИ ОРҚАЛИ МУСТАҲКАМЛИГИНИ ҲАМДА ИШЛАШ УНУМИНИ ОШИРИШ. *Oriental renaissance: Innovative, educational, natural and social sciences*, 2 (2), 847-856.
37. Muxtorov, Abdumajidxon Murodxon O'G'Li, Turg'Unbekov, Axmadbek Mahmudjon O'G'Li, & Mahmudov, Abdulrasul Abdumajidovich (2022). AVTOMOBIL OLD OYNAKLARINI VAKUURLASH JARAYONIDA VAKUURLASH TEXNOLOGIYASINING AHAMIYATI. *Oriental renaissance: Innovative, educational, natural and social sciences*, 2 (3), 93-102.
38. Мухторов А.М., Турғунбеков А.М. Исследование работоспособности дорожных фрез в условиях эксплуатации // *Universum: технические науки* : электрон. научн. журн. 2022. 5(98). URL: <https://7universum.com/ru/tech/archive/item/13633> (дата обращения: 07.05.2022).
39. Ahmadbek M. o. biyomekanik modellashtirishni tanlash usuli. // *Universum: texnik fanlar: elektron. ilmiy. journe.* 2022. 5(98). Pochta manzili: <URL>

- <https://7universum.com/ru/tech/archive/item/13722> (murojaat sanasi: 17.05.2022).
40. Turg'unbekov A. M., Mamatqulova D. N. yo'llarni sovuq melioratsiya qilish uchun frezani loyihalash va ish jarayoni. // Universum: texnik fanlar: elektron. ilmiy. journe. 2022. 5(98). Pochta manzili: <URL> <https://7universum.com/ru/tech/archive/item/13808> (murojaat sanasi: 23.05.2022)
41. Ergashev Ilhomjon Olimjonovich, & Mahmudov Nasimbek Odilbekovich. (2022). Calculation of Carrier and Interchangeable Element Combination. *Eurasian Journal of Engineering and Technology*, 5, 68–73. Retrieved from <https://www.geniusjournals.org/index.php/ejet/article/view/1162>
42. 8. Fayzimatov Shukhrat Nomonovich, Ergashev Ilhomjon Olimjonovich, & Valikhonov Dostonbek Azim o'g'li. (2022). Effects Of Crushing on Cutting and Cleaning of Surface Facilities in Cutting and Processing of Polymer Materials. *Eurasian Research Bulletin*, 4, 17–21. Retrieved from <https://www.geniusjournals.org/index.php/erb/article/view/353>